



### Specifications

<b>Input Voltage :</b>	24V DC / 110V AC / 230V AC
<b>Wattage</b>	<b>11W</b>
<b>Operating Temp</b>	0 to 70 degree
<b>Control Gear</b>	Onboard
<b>CRI</b>	82 Typical
<b>Luminaire body</b>	SMD LED strip
<b>No. of LED's</b>	48
<b>LED color</b>	Cool white / 6500K
<b>O/P Power</b>	11W
<b>O/P Current</b>	0.47A
<b>LED Make</b>	Edison / Everlight / Osram
<b>Lumens</b>	1100 Lm
<b>Light View Angle</b>	120 °
<b>Lamp Housing</b>	Aluminium with Toughen Glass
<b>Fastening</b>	End Brackets
<b>Lamp Weight</b>	Approx. 675 Grams
<b>Avg Life Hours</b>	30,000 Hrs
<b>Cable Length</b>	3 Meters



### Features

- Ideal for CNC & SPM Machines
- CE Certified
- Coolant, Water & dust proof hence suitable for wet & dry applications
- Aluminium Housing with Toughened Glass
- 360 degree Adjustable viewing angle
- Excellent Cool Day Light
- Fixed Mounting
- IP 65 grade protection
- Used good quality Aluminium with excellent anti-corrosion and good heat dissipation
- Easily Mountable either Vertically or Horizontally
- Stringently checked on various criterion of performance
- Longer Functional Life

### Ordering Code

SMC-CNC-AH-2-1-L	24 VDC	11 W
SMC-CNC-AH-2-2-L	110 VAC	11 W
SMC-CNC-AH-2-3-L	230 VAC	11 W

### Dimensional Drawings

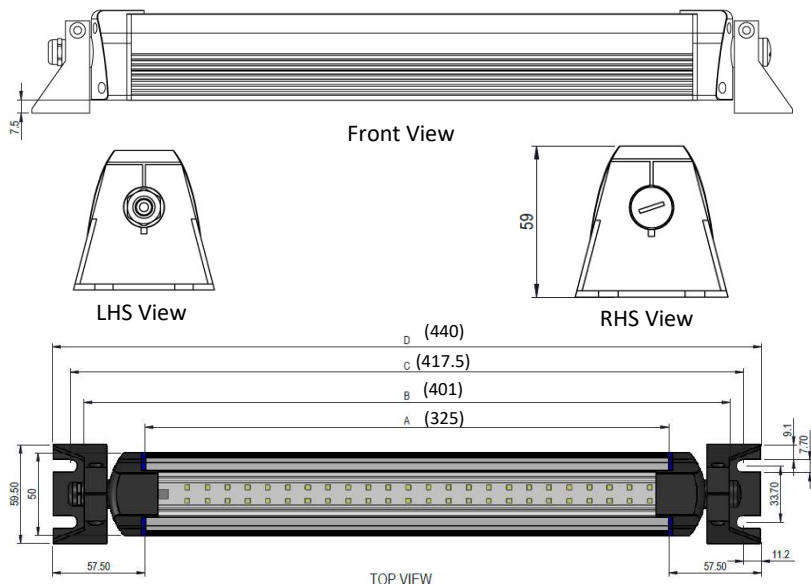

ISO 9001:2015 Certified